

KLIXON | 1NT SERIES

Fixed Temperature Thermostats

WORLD CLASS PERFORMANCE

The 1NT has been designed to be applied for use in many HVAC and appliance products as either a regulating or over-temperature safety switch.

The 1NT uses Klixon® technology and is available in several mounting options.

Sensata Technologies has been a leading global supplier of pressure sensors and switches for over 50 years.

Key Features

- ISO9001: 2000 certification
- Factory inspected for continuity and contact resistance
- Global sales and technical support
- Ambient temperature rating from -40°C to 240°C (-40°F to 464°F)
- 1NT base provides:
 - Low cost
 - High temperature capability
 - Clean processing
 - High impact strength
 - Low static generation
- Bi-metal disc is factory pre-set to achieve:
 - Operation at requested temperatures
 - Tamperproof settings
- Product innovations include:
 - Solid metal-to-metal terminal construction
 - Current free spring
 - One piece transfer mechanism
- Switch actions:
 - Automatic reset: Available with both normally open and normally closed switch logic
 - Manual reset: Mechanical reset device
 - Trip free manual reset: UL M2 class rating that resists consumer tampering
 - One shot: meets agency requirements for single operation device

Applications

- Microwave ovens
- Sandwich makers
- Rice cookers
- Hair dryers
- Fan heaters
- Vacuum cleaners
- Gas / electric furnaces
- Espresso machines
- Tea makers
- Automotive / truck



Klixon® is a registered trademark of Sensata Technologies, Inc.

Available Constructions

High Profile Construction

Options shown: 90° - 1/4" Q.C. terminals with Surface mount flange

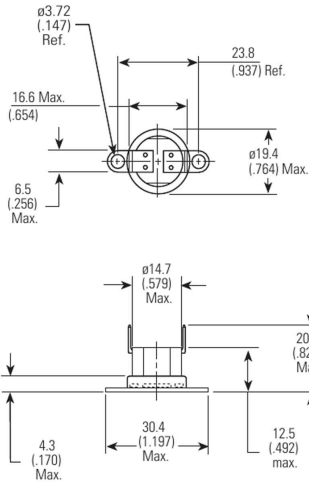

Part Types by Construction

1NT01 Auto Reset / Silver Contacts
 1NT11 Auto Reset / Gold Contacts
 1NT09 One Shot: -35°C (-31°F) Reset
 1NT10 One Shot: 0°C (32°F) Reset

Low Profile Construction

4 Post

Options shown: 45° - 1/4" Q.C. terminals with 4 post and flat Al cup

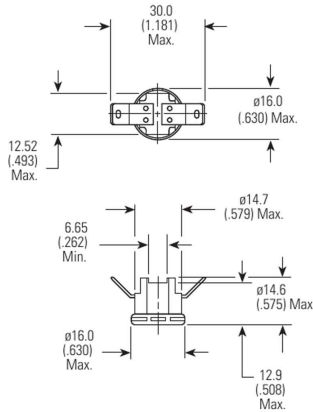

1NT02 Auto Reset / Silver Contacts
 1NT02TL Low Profile / One Shot
 1NT20 Auto Reset / Gold Contacts

Manual Reset Construction

Options shown: Flat 1/4" Q.C. terminals with Airstream mount cup

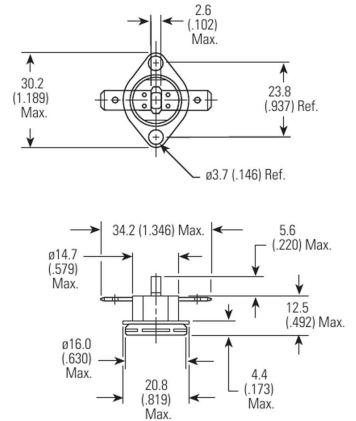

1NT08 Manual Reset / Silver Contacts
 1NT12 Manual Reset / Gold Contacts
 1NT15 Trip Free MR / Silver Contacts
 1NT19 Trip Free MR / Gold Contacts

All dimensions mm (in.)

Numbering System

Part Number

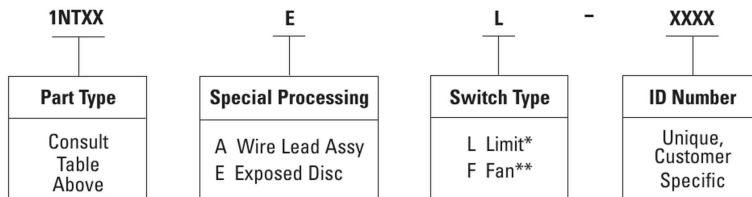

Temperature Code

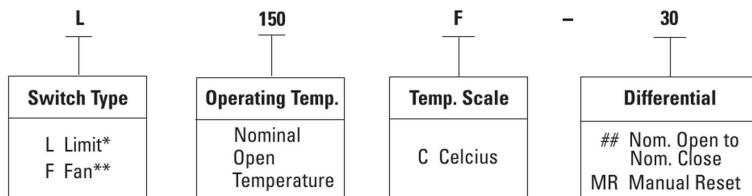

* Limit switch opens on temperature rise

** fan switch closes on temperature rise

1NT Series Electrical Ratings

The 1NT series of thermostats has been recognized by safety agencies, including UL, Canadian-UL and KEMA. Agency ratings are presented below as a general guide. However, the temperature settings, mechanical, electrical, thermal and environmental conditions of the specific application may differ significantly from agency test conditions. Therefore, the user must not rely solely on the agency ratings presented here, but must perform its own testing of the product to confirm that the thermostat selected will operate as intended over the useful design life of the user's applications.

UL and C-UL

Type	Max. Temp.		Cycles (X 1000)	Electrical Rating	
	°C	°F			
NT01, 02	204	400	100	120 Vac	0 - 9 amps 10 - 17 amps*
				240 Vac	0 - 5 amps 6 - 17 amps*
				277 Vac	7.2 amps
1NT08, 15, 08E**	204	400	1 + 5	240 Vac	25 amps
1NT09, 10	204	400	1-Shot	240 Vac 277 Vac	25 amps 7.2 amps
1NT11, 20	204	400	100	125 VA 30 Vdc	1 amp
1NT12, 19	204	400	1 + 5	125 VA	
1NT01E, 02E**	204	400	100	120 Vac	10 amps

* UL rated at these current levels at specific open/close temperatures. When applying to these electrical levels, nominal open/close temperatures must be considered to determine if the thermostat selected will operate as intended in the user's application. Please consult a Sensata Engineer for additional clarification.

** "E" means exposed disc.

KEMA

Type	Max. Temp. °C	Cycles (X 1000) <i>(unless otherwise specified)</i>	Electrical (Rating)*	
1NT01, 02	204	100	240 Vac	0 - 5 amps (1.66)A 6 - 13.5 amps (1.66)A**
		30 30		240 Vac 16(5)A 400 Vac 4(1)A
1NT02TL	204	1 cycle	240 Vac	16(5)A
1NT08	204	10	240 Vac	16(5)A
		10	400 Vac	4(1)A
1NT09	204	1 cycle	240 Vac	16(5)A
1NT11	204	100	30 Vdc	1A
1NT15	204	10	240 Vac	16(5)A
1NT20	204	100	30 Vdc	1A

* Parenthesis indicate inductive load ratings.

** KEMA rated at these current levels at specific open/close temperatures. When applying to these electrical levels, nominal open/close temperatures must be considered to determine if the thermostat selected will operate as intended in the user's application. Please consult a Sensata Engineer for additional clarification.

Standard Temperatures, Tolerances and Differential

Automatic Reset Thermostats

Nominal Top Temperature		Min. Bottom Temperature		Differential		Standard Tolerances			
						Open		Close	
°C	°F	°C	°F	°C	°F	°C	°F	°C	°F
18 to 27	65 to 80	-33	-26	11 to 16	20 to 29	±3.0	±5.5	±4.0	±7.5
				17 to 21	30 to 38	±3.0	±5.5	±4.5	±8.5
				22 to 33	39 to 59	±3.0	±5.5	±5.5	±10.0
28 to 80 and *81 to 93	81 to 176 and 177 to 199	-33	-26	11 to 13	20 to 23	±3.0	±5.5	±4.0	±7.5
				14 to 16	24 to 29	±3.0	±5.5	±4.5	±8.5
				17 to 33	30 to 59	±3.0	±5.5	±5.0	±9.0
*94 to 121	*200 to 249	50	122	11 to 16	20 to 29	±3.5	±6.5	±4.5	±8.5
				17 to 21	30 to 38	±3.5	±6.5	±5.5	±10.0
				22 to 33	39 to 59	±3.5	±6.5	±6.5	±12.0
				34 to 55	60 to 99	±5.5	±10.0	±10.0	±20.0
122 to 149	250 to 300	50	122	14 to 21	24 to 38	±4.0	±7.5	±5.5	±10.0
				21 to 33	39 to 59	±4.0	±7.5	±8.0	±14.5
				34 to 55	60 to 99	±5.5	±10.0	±11.0	±20.0
150 to 177	301 to 399	50	122	22 to 33	39 to 59	±5.0	±9.0	±9.0	±16.5
				34 to 44	60 to 79	±5.5	±10.0	±11.0	±20.0
				45 to 55	80 to 99	±5.5	±10.0	±11.0	±20.0
178-204**	351 to 399	50	122	22 to 33*	39 to 59	±5.0	±9.0	±9.0	±16.5
				34 to 44	60 to 79	±5.5	±10.0	±10.0	±20.0
				45 to 55	80 to 99	±5.5	±10.0	±10.0	±20.0

* Not valid for Fan Devices

** Top Temp for Fan Devices cannot exceed 380°F (193°C)

Manual Reset and One-Shot Thermostats

Nominal Top Temperature		Open Tolerances	
°C	°F	°C	°F
<60	<140	±4.0	±7.5
61 TO 160	141 to 320	±5.0	±9.0
161 TO 204	321 to 399	±6.0	±11.0

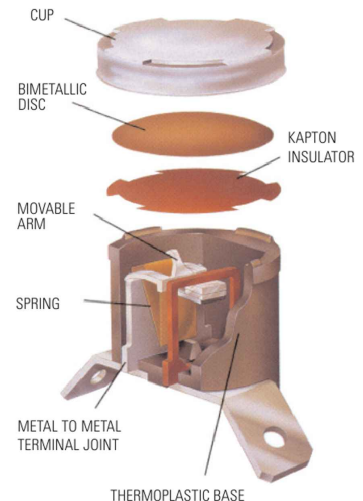

Accessories and Options

Cup Styles

<p>Airstream Mount Integral Cup 57611 Material: Aluminum Available mounting rotation relative to terminals - 0° or 90° Closed Bottom Only</p> <p>Top View Dimensions: - Overall width: 30.2 (1.189) Max. - Terminal spacing: 23.8 (937) Ref. - Terminal diameter: $\phi 3.7$ (.146) Ref. - Max. height from centerline: 20.8 (.819) Max. - Bottom width: 16.0 (.630) Max. - Bottom height: 4.5 (.177) Max. - Offset from centerline: 0.34 (.013) Ref.</p> <p>Side View Dimensions: - Overall height: 16.0 (.630) Max. - Bottom thickness: 0.30 (.012) Ref.</p>	<p>Flat Cup 73926 Materials: Aluminum, Stainless Steel or Copper</p> <p>Top View Dimensions: - Overall width: 16.26 (.640) Max.</p> <p>Side View Dimensions: - Overall height: 3.94 (.155) Max. - Bottom thickness: 0.30 (.012) Ref.</p>	<p>3NT Flange Cup 57366 Material: Aluminum or Copper Closed Bottom Only</p> <p>Top View Dimensions: - Overall width: 16.5 (.650) Max.</p> <p>Side View Dimensions: - Overall height: 5.5 (.217) Max. - Bottom thickness: 0.5 (.020) Ref.</p>	<p>Airstream Mount Integral Cup 27185 Material: Stainless Steel Available mounting rotation relative to terminals 0°, 45° or 90° with Closed Bottom 0° or 90° with Open Bottom</p> <p>Top View Dimensions: - Overall width: 30.2 (1.189) Max. - Terminal spacing: 23.8 (937) Ref. - Terminal diameter: $\phi 3.7$ (.146) Ref. - Max. height from centerline: 20.8 (.819) Max. - Bottom width: 16.0 (.630) Max. - Bottom height: 4.4 (.173) Max. - Offset from centerline: 0.25 (.010) Ref.</p> <p>Side View Dimensions: - Overall height: 16.0 (.630) Max. - Bottom thickness: 0.30 (.012) Ref.</p> <p>Note: Available Diameter Mounting Holes with open bottom: 3.7 (.146) with closed bottom: 3.7(.146) / 4.2(.165) or none</p>
<p>Airstream Mount Integral Cup (slotted mounting holes) 57367 Material: Aluminum Available mounting rotation relative to terminals - 0° or 90° Closed Bottom Only</p> <p>Top View Dimensions: - Overall width: 32.15 (1.266) Max. - Terminal spacing: 24.5 (965) Ref. - Terminal diameter: $\phi 3.7$ (.146) Ref. - Max. height from centerline: 20.15 (.793) Max. - Offset from centerline: 4.5 (.177) Ref.</p> <p>Side View Dimensions: - Overall height: 16.5 (.650) Max. - Bottom thickness: 0.5 (.020) Ref.</p>	<p>Wide-Eared Integral Cup 57608 Material: Stainless Steel Available mounting rotation relative to terminals - 0° or 90° Closed Bottom Only</p> <p>Top View Dimensions: - Overall width: 43.28 (1.704) Max. - Terminal spacing: 31.75 (1.250) Ref. - Terminal diameter: $\phi 4.75$ (.187) Ref.</p> <p>Side View Dimensions: - Overall height: 16.0 (.630) Max. - Bottom thickness: 0.25 (.010) Ref.</p>	<p>"Tear-Drop" Integral Cup 57609 Material: Stainless Steel Available mounting rotation relative to terminals - 0° or 90° Closed Bottom Only</p> <p>Top View Dimensions: - Overall width: 31.75 (1.250) Ref. - Terminal spacing: 21.72 (.855) Max. - Terminal diameter: $\phi 4.75$ (.187) Ref.</p> <p>Side View Dimensions: - Overall height: 16.0 (.630) Max. - Bottom thickness: 0.25 (.010) Ref.</p> <p>Note: 90° mounting option is also available with 57612 teardrop shaped stiffening flange upon customer request.</p>	<p>Large Oval Integral Cup 57602 Material: Aluminum Available mounting rotation relative to terminals - 0° or 90° with Open Bottom 0°, 45° or 90° with Closed Bottom</p> <p>Top View Dimensions: - Overall width: 51.1 (2.010) Max. - Terminal spacing: 39.67 (1.562) Ref. - Terminal diameter: $\phi 3.7$ (.146) Ref.</p> <p>Side View Dimensions: - Overall height: 16.0 (.630) Max. - Bottom thickness: 0.33 (.013) Ref.</p>
<p>Flanges</p> <p>Fixed Rotation Surface Mount Flange 57336 Available mounting rotation relative to terminals - 90° with Aluminum - 0°, 90° / or 57°, 127°, 135° CCW with Nickel Plated Steel</p> <p>Top View Dimensions: - Overall width: 23.8 (937) Ref. - Terminal diameter: $\phi 3.72$ (.147) Ref.</p> <p>Side View Dimensions: - Overall height: 18.4 (.724) Max. - Bottom thickness: 0.38 (.015) Ref.</p>	<p>Loose Ear Surface Mount Flange 27183 Material: Aluminum</p> <p>Top View Dimensions: - Overall width: 18.4 (.724) Max. - Hole diameter: $\phi 14.9$ (.587) Ref.</p> <p>Side View Dimensions: - Overall height: 18.4 (.724) Max. - Bottom thickness: 0.38 (.015) Ref.</p>	<p>Wide Eared - Fixed Rotation Mounting Flange 57337 Material: Nickel Plated Steel Available mounting rotation relative to terminals - 45° CCW</p> <p>Top View Dimensions: - Overall width: 43.28 (1.704) Max. - Terminal spacing: 31.75 (1.250) Ref.</p> <p>Side View Dimensions: - Overall height: 18.4 (.724) Max. - Bottom thickness: 0.38 (.015) Ref.</p>	<p>Bolt On Assembly 73972 Thread Specs: Metric: M4 x 0.7 - 6G M5 x 0.8 - 6G Stud Length: Metric: 6.15, 7.00, 8.00, 9.00 (with M4) 8.00 (with M5) English: 6 x 32 - 1/2" Long 8 x 32 - 1/2" Long Material: Stud: Zinc Plated Steel Cap: Aluminum</p> <p>Top View Dimensions: - Overall width: 15.90 (.626) Max.</p> <p>Side View Dimensions: - Overall height: 13.74 (.541) Max. - Stud length: Lgth. Varies</p>

All dimensions mm (in.)

Accessories and Options (cont.)

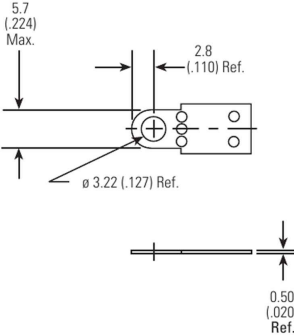
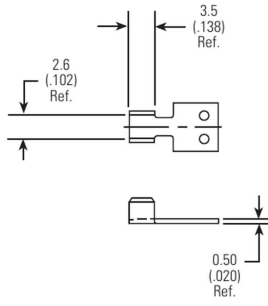
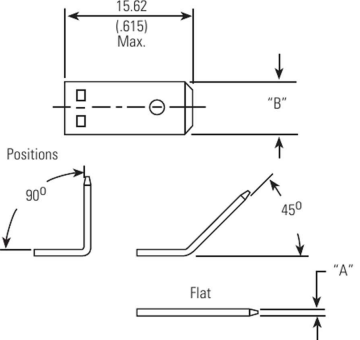
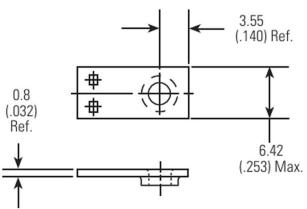
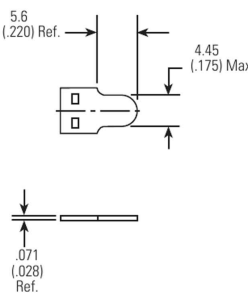
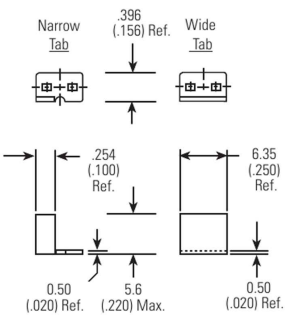
<p>Terminals</p> <p>Solder Terminal 27182* Material: Tin Plated Brass</p> 	<p>Crimp Terminal 27184* Material: Tin Plated Brass</p> 	<p>Quick Connects</p> <table border="0"> <tr> <td></td> <td>27132</td> <td>27162*</td> <td>27163</td> </tr> <tr> <td>Thickness (A):</td> <td>0.8(.031)</td> <td>0.5(.020)</td> <td>0.8(.031)</td> </tr> <tr> <td>Width (B):</td> <td>6.3(.250)</td> <td>4.8(.187)</td> <td>4.8(.187)</td> </tr> <tr> <td>Materials:</td> <td colspan="3">Brass - Solid, Ni, Ag, or Tin Plated Steel - Nickel Plated</td> </tr> </table> 		27132	27162*	27163	Thickness (A):	0.8(.031)	0.5(.020)	0.8(.031)	Width (B):	6.3(.250)	4.8(.187)	4.8(.187)	Materials:	Brass - Solid, Ni, Ag, or Tin Plated Steel - Nickel Plated		
	27132	27162*	27163															
Thickness (A):	0.8(.031)	0.5(.020)	0.8(.031)															
Width (B):	6.3(.250)	4.8(.187)	4.8(.187)															
Materials:	Brass - Solid, Ni, Ag, or Tin Plated Steel - Nickel Plated																	
<p>Screw Terminal 57200 Material: Nickel Plated Steel M3 x 0.5 Class 6H Thread</p> 	<p>Weld Terminal 57201 Material: Nickel Plated Steel</p> 	<p>Weld Terminal 57312* Material: Nickel Plated Steel</p> 																

*10A Max. on all terminals 0.51 (.020) thick
All dimensions mm (in.)

1NT Series Agency Listings

Type	Agency Region		
	UL/C-UL N. America	KEMA Europe	METI Japan
1NT01, 02	•	•	•
1NT08	•	•	•
1NT09, 10	•	•	•
1NT11, 12, 19, 20	•	•	•
1NT15	•	•	•
1NT01E, 02E	•	•	•
Reference Numbers	File: E9977 Category: XAPX2 XAPX8	KEMA cert # EN2014531.16	

Important Notice

Users are solely responsible for design application and function of the end use product. Users must evaluate the suitability of these devices to their application with respect to temperature settings, mechanical cycle life, electrical loading and environmental conditions. These devices are not environmentally sealed and have exposed electrical components. They are not intended for use in applications where exposure to condensed or dripping liquids, immersion in liquid, or exposure to other environmental contaminants may occur. In such cases, use of environmentally sealed devices such as the 3NT is recommended. Excessive mechanical cycling, high electrical loading or exposure to liquids or environmental contaminants as noted above can compromise electrical insulating properties of the device. Such conditions may result in insulation breakdown and accompanying localized electrical heating. The device may remain permanently closed or open as a result of these conditions, as well as at normal end-of-life.

Sample Order Placement

To enable Sensata Technologies to serve you in a quicker, more efficient manner, please be prepared to provide the following information when requesting samples:

1. Detailed application description
2. Estimated yearly usage
3. Opening and closing temperatures
4. Max. temperature tolerances allowable
5. Switch type
6. Mounting style desired
7. Terminal orientation and material
8. Electrical load

Other conditions which are likely to affect the 1NT operation should also be described. These include:

1. Maximum temperature exposure
2. Location with respect to heat source
3. Temperature transfer medium (air, metal surface, etc)
4. Possible contamination sources (lint, chemical fumes, liquid, condensation, humidity, etc.)

When ordering thermocouple samples, specify whether J, K, or T type and the lead length desired. Standard wire size is 30 Ga.

Thermostat Handling Tips

1. Exposed disc devices should be kept free of dust and particulates, liquid and condensation. The face of the disc should never be snapped.
2. Mounting screws and drivers for use with smaller integral cups and flanges should be sized to provide adequate clearance to the thermostat body.
3. The installation force applied to the cup face should not exceed 66.7N (15 lbs.).
4. The maximum reset force on the manual reset and trip free button is 22.2N (5 lbs.).



The World Depends on Sensors and Controls

Important Notice: Sensata Technologies reserves the right to make changes to, or to discontinue, any product or service identified in this publication without notice. Before placing orders, users should obtain the latest version of the relevant information to verify that the information being relied upon is current.

Sensata Technologies assumes no responsibility for customers' product designs or applications. Users must determine the suitability of the Sensata device described in this publication for their application, including the level of reliability required. Many factors beyond Sensata's control can affect the use and performance of a Sensata product in a particular application, including the conditions under which the product is used and the time and environmental conditions in which the product is expected to perform. As these factors are uniquely within the user's knowledge and control, it is essential that the user evaluate the Sensata product to determine whether it is fit for a particular purpose and suitable for the user's application.

Sensata Technologies products are sold subject to Sensata's Terms and Conditions of Sale which can be found at www.sensata.com/terms.htm

Printed in U.S.A. Revised October 7, 2010

