

JUMO dTRANS T05

Programmable 2-Wire Transmitter

- For installation into terminal head form B
- For installation on DIN rail

Brief description

The transmitters detect sensor signals by means of RTD temperature probes, thermocouples, resistance transmitters, or resistors/potentiometers. When using a resistor/potentiometer or RTD temperature probe, the sensor connection on the input side can be connected with a 2-wire, 3-wire, or 4-wire circuit. Voltage signals in the range from -100 to +1100 mV can also be detected. Depending on the selected measuring input the linearization variants linear, temperature-linear, and the possibility of an easy configurable as well as customer-specific linearization are available.

Type 707050 delivers 4 to 20 mA as an output signal. Type 707051 offers an output signal of 4 to 20 mA or 0 to 10 V. The measuring input and the output signal are electrically isolated from each other. Reversion of the output signal is possible for both types.

The transmitter configuration with respect to probe type, connection technology of the probe, measuring range (freely adjustable), and linearization is carried out by means of a setup program on the PC. The connection to the PC is established via a USB interface which does not require additional auxiliary voltage. Via the USB interface the min./max. process value and the min./max. operating temperature detected by the transmitter can be read and the sensor wiring can be checked online.

The operating status of the transmitter is indicated by a two-color control LED (red/green). This is lit green during operation without malfunctions. If a malfunction such as a probe break occurs then the signal starts flashing.



Type 707050 (dTRANS T05 B)



Type 707051 (dTRANS T05 T)

Block diagram

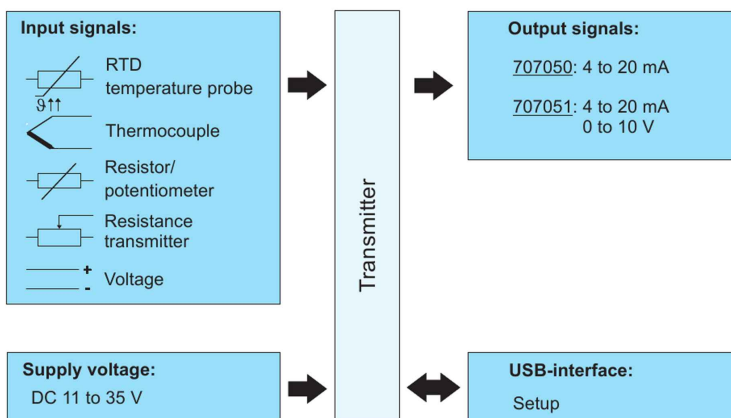

Special features

- Measuring input for RTD temperature probe, thermocouple, resistor/potentiometer, resistance transmitter, and voltage
- Input and output are electrically isolated
- Control LED (red/green)
- Configuration directly via USB cable (Mini-B) without additional auxiliary voltage
- Customer-specific linearization
- Detection of the min./max. process value (drag pointer function including point in time)
- Option to specify the temperature in °F for temperature sensors
- Type 707051 available with screw terminals or spring-cage terminals

Technical data

Analog input

All analog inputs are equipped with a digital filter of second order (filter constant adjustable from 0 to 10 s) and have a sampling rate of > 2 measurements per second.

RTD temperature probe

Designation	Standard	ITS	Connection type	Measuring range in °C		Measuring accuracy ^a
				Min.	Max.	
Pt100	IEC 60751:2008	ITS-90	2/3-wire	-100	200	±0.2 K
Pt500			2/3-wire	-200	850	±0.4 K
Pt1000			4-wire	-100	200	±0.1 K
$T_K = 3.85 \times 10^{-3} 1/K$			4-wire	-200	850	±0.2 K
Pt100	GOST 6651-2009 A.2	ITS-90	2/3-wire	-100	200	±0.2 K
$T_K = 3.917 \times 10^{-3} 1/K$			2/3-wire	-200	850	±0.4 K
			4-wire	-100	200	±0.15 K
			4-wire	-200	850	±0.25 K
			Pt50	2/3-wire	-200	850
$T_K = 3.91 \times 10^{-3} 1/K$	4-wire	-200	850	±0.3 K		
Ni100	DIN 43760	IPTS-68	2/3-wire	-60	250	±0.4 K
$T_K = 6.18 \times 10^{-3} 1/K$			4-wire	-60	250	±0.2 K
			Ni500	2/3-wire	-60	250
$T_K = 6.18 \times 10^{-3} 1/K$			4-wire	-60	250	±0.2 K
			Ni1000	2/3-wire	-60	250
$T_K = 6.18 \times 10^{-3} 1/K$			4-wire	-60	250	±0.2 K
Ni 100	GOST 6651-2009 A.5	ITS-90	2/3-wire	-60	180	±0.4 K
$T_K = 6.17 \times 10^{-3} 1/K$			4-wire	-60	180	±0.2 K
Cu50	GOST 6651-2009 A.3	ITS-90	2/3-wire	-180	200	±0.5 K
$T_K = 4.28 \times 10^{-3} 1/K$			4-wire	-180	200	±0.3 K
			Cu100	2/3-wire	-180	200
$T_K = 4.28 \times 10^{-3} 1/K$			4-wire	-180	200	±0.2 K

^a The accuracy value refers to the complete measuring range.

Connection type	2-wire, 3-wire, or 4-wire circuit
Sensor lead resistance	
- For 3/4-wire circuit	≤ 11 Ω per line
- For 2-wire circuit	Measuring resistance + ≤ 22 Ω inner line resistance
Sensor current	< 0.3 mA

Thermocouples

Designation	Type	Standard	ITS	Measuring range in °C		Measuring accuracy ^a
				Min.	Max.	
Pt13Rh-Pt	R	IEC 584-1	ITS-90	-50	1768	± 0.15 % from +50 °C
Pt10Rh-Pt	S	IEC 584-1	ITS-90	-50	1768	± 0.15 % from +20 °C
Pt30Rh-Pt6Rh	B	IEC 584-1	ITS-90	0	1820	± 0.15 % from +400 °C
Fe-CuNi	J	IEC 584-1	ITS-90	-210	1200	± 0.1 % from -100 °C
Cu-CuNi	T	IEC 584-1	ITS-90	-270	400	± 0.1 % from -150 °C
NiCr-CuNi	E	IEC 584-1	ITS-90	-270	1000	± 0.1 % from -80 °C
NiCr-Ni	K	IEC 584-1	ITS-90	-270	1372	± 0.1 % from -80 °C
NiCrSi-NiSi	N	IEC 584-1	ITS-90	-270	1300	± 0.1 % from -80 °C
Fe-CuNi	L	DIN 43710	IPTS-68	-200	900	± 0.1 %
Cu-CuNi	U	DIN 43710	IPTS-68	-200	600	± 0.1 % from -100 °C
Chromel-Copel (Ni9.5Cr-Cu44Ni)	L	GOST R 8.585-2001	ITS-90	-200	800	± 0.1 % from -80 °C
Chromel-Alumel		GOST R 8.585-2001	ITS-90	-270	1372	± 0.1 % from -80 °C
W5Re-W20Re	A1	GOST R 8.585-2001	ITS-90	0	2500	± 0.15 %
W5Re-W26Re	C	ASTM E230/E230M-11	ITS-90	0	2315	± 0.15 %
W3Re-W25Re	D	ASTM E1751/E1751M-09	ITS-90	0	2315	± 0.25 %
PL II (Platinel ^b II)		ASTM E1751/E1751M-09	ITS-90	0	1395	± 0.15 %

Cold junction	Pt1000 internal or external cold junction; temperature adjustable 0 to 80 °C
Cold junction accuracy	± 1 K

^a The accuracy values refer to the complete measuring range.

^b Platinel is a registered trademark of Engelhardt Corp.

Resistance transmitter and resistor/potentiometer

Designation	Measuring range	Measuring accuracy
Resistance transmitter	Up to 10000 Ω	±10 Ω
Resistor/potentiometer	≤ 400 Ω	±400 mΩ
	≥ 400 Ω to ≤ 4000 Ω	± 4 Ω
	> 4000 Ω to ≤ 10000 Ω	±10 Ω
Connection type	Resistance transmitter: 3-wire circuit (A = Start, S = Slider, E = End) Resistor/potentiometer: 2-wire circuit, 3-wire circuit, and 4-wire circuit	
Sensor lead resistance	≤ 11 Ω per line for 2-wire circuit, 3-wire circuit, and 4-wire circuit	

Direct current

Designation	Measuring range	Accuracy ^a	Input resistance
Input for mV generator	-100 to 1100 mV	±0.05 %	R _E ≥ 1 MΩ

^a The accuracy value refers to the complete measuring range.

Measuring circuit monitoring

	Type 707050	Type 707051
Underrange	Linear drop up to 3.8 mA (According to NAMUR recommendation 43)	Linear drop up to 3.8 mA (According to NAMUR recommendation 43) Linear drop up to -0.12 V
Overrange	Linear increase up to 20.5 mA (According to NAMUR recommendation 43)	Linear increase up to 20.5 mA (According to NAMUR recommendation 43) Linear increase up to 10.31 V
Probe short-circuit/probe and cable break	RTD temperature probe: (configurable) $\leq 3.6 \text{ mA}, \geq 21.7 \text{ mA}$ Or free setting: 3.6 mA to 23 mA	RTD temperature probe: (configurable) $\leq 3.6 \text{ mA}, \geq 21.7 \text{ mA}$ Or free setting: 3.6 mA to 23 mA
		$\leq -0.2 \text{ V}, \geq 11.0 \text{ V}$ Or free setting: -0.25 V to 11.875 V
	Thermocouple: (configurable) ^a $\leq 3.6 \text{ mA}, \geq 21.7 \text{ mA}$ Or free setting: 3.6 mA to 23 mA	Thermocouple: (configurable) ^a $\leq 3.6 \text{ mA}, \geq 21.7 \text{ mA}$ Or free setting: 3.6 mA to 23 mA
		$\leq -0.2 \text{ V}$ or $\geq 11.0 \text{ V}$ Or free setting: -0.25 V to 11.875 V
Current limiting in the event of a probe short circuit or probe break	$\leq 23 \text{ mA}$	

^a For thermocouples and mV generator a probe short-circuit detection is not possible.

Output

	Type 707050	Type 707051
Output signal	Load-independent direct current: Free setting: 4 to 20 mA or 20 to 4 mA	Load-independent direct current: Free setting: 4 to 20 mA or 20 to 4 mA
		Voltage signal: Free setting: 0 to 10 V or 10 to 0 V
Electrical isolation Test voltage	Between input and output: $\dot{U} = 3.75 \text{ kV}/50 \text{ Hz}$	Between input and output: $\dot{U} = 1.875 \text{ kV}/50 \text{ Hz}$
Transmission behavior	Linear, temperature-linear Customer specific Reversion of the output signal	
Step response 0 to 100 %	$< 2 \text{ s}$ (with filter constant 0 s)	
Switch-on delay	5 s (correct measured value after the supply voltage is applied)	
Current output		
Load (R_b)	$R_b = (U_b - 11 \text{ V})/0.022 \text{ A}$	
Load error	$\leq \pm 0.02 \text{ \%}/100 \Omega$	
Calibration conditions/accuracy	DC 24 V at approx. 22 °C/ $\pm 0.05 \text{ \%}$ ^a	
Voltage output		
Load resistance	$\geq 2 \text{ k}\Omega$	
Load influence	$\pm 15 \text{ mV}$	
Residual ripple	$\pm 1 \text{ \%}$ referring to 10 V, 0 to 90 kHz	
Calibration conditions/accuracy	DC 24 V at approx. 22 °C/ $\pm 0.05 \text{ \%}$ ^b	

^a All specifications refer to the measuring range end value of 20 mA

^b All specifications refer to the measuring range end value of 10 V

Customer-specific linearization

Method	Characteristics
Pairs of values	Max. number: 40
	Interpolation: linear
Formula	Number of coefficients: 5
	Polynomial: 4th order

Voltage supply

	707050	707051
Voltage supply (U_b)	DC 11 to 35 V (with reverse voltage protection ^a) Only for operation in SELV, PELV current circuits according to DIN EN 50178	
Voltage supply error	$\leq \pm 0.01$ %/V deviation from 24 V ^b	

^a Prerequisite for use of the voltage output of type 707051 is a supply voltage of at least 15 V

^b All specifications refer to the measuring range end value of 20 mA

Environmental influences

	707050	707051
Operating temperature range	-40 to +85 °C	-10 to +70 °C
Storage temperature range	-40 to +100 °C	-10 to +70 °C
Temperature influence		
RTD temperature probe	$\leq \pm 0.005$ %/K deviation from 22 °C ^a	
Resistance transmitter	$\leq \pm 0.01$ %/K deviation from 22 °C ^a	
Resistor/potentiometer	$\leq \pm 0.01$ %/K deviation from 22 °C ^a	
Thermocouple	$\leq \pm 0.005$ %/K deviation from 22 °C ^a (plus accuracy of the cold junction)	
Direct current	$\leq \pm 0.01$ %/K deviation from 22 °C ^a	
Long-term stability	≤ 0.1 K/year ^b or ≤ 0.05 %/year ^c	
Resistance to climatic conditions		
In terminal head, form B	Rel. humidity ≤ 95 %, with condensation	
Open assembly	Rel. humidity ≤ 95 %, without condensation	
On DIN rail	Rel. humidity ≤ 95 %, without condensation	
Vibration resistance		
DIN EN 60068-2-6	Max. 2 g at 10 to 2000 Hz	
DIN EN 60068-2-27	Shock; 10 g/6 ms	
Germanischer Lloyd	Characteristic line 2	
Electromagnetic compatibility (EMC)	According to DIN EN 61326-1	
Interference emission	Class B	
Interference resistance	Industrial requirements	

	707050	707051
IP protection type		
In terminal head, form B	IP54/IP65 (depending on the version)	
Open assembly	IP00	
On DIN rail		IP20

^a All specifications refer to the measuring range end value of 20 mA or 10 V

^b Under calibration conditions

^c % refer to the set measuring span. The greater value of the long-term stability applies.

Case

	707050	707051
Material	Polycarbonate UL 94 V2 (grouted)	Polybutylene terephthalate UL 94 V0
Terminal type	Screw terminals:	Screw terminals:
Wire type	Rigid and flexible wires ≤ 1.75 mm ² ; Max. torque 0.6 Nm	Rigid and flexible wires 0.2 mm ² to 2.5 mm ² AWG/kcmil min. 26, max 12 Stripping length 12 mm Torque 0.5 - 0.6 Nm
		Spring-cage terminals Rigid and flexible wires 0.2 mm ² to 2.5 mm ² AWG/kcmil min. 26, max 12 Stripping length 8 mm
Assembly type	In terminal head, form B (DIN EN 50446); In the surface-mounted case (see accessories); In the control cabinet (mounting element required)	On DIN rail TH 35-7.5 Or TH 35-15 (DIN EN 60715);
Installation position	Any	
Weight	~ 35 g	~ 50 g

Approval/approval marks

None

Setup program

The transmitter is configured on the PC with the setup program. The connection between transmitter and PC is established via a USB cable. The transmitter interface is a USB port of the Mini-B type. It supports standard 2.0 "Full Speed". Once configuration of the transmitter has been completed make sure that the attached hinged-on lid is back on the transmitter's USB interface.

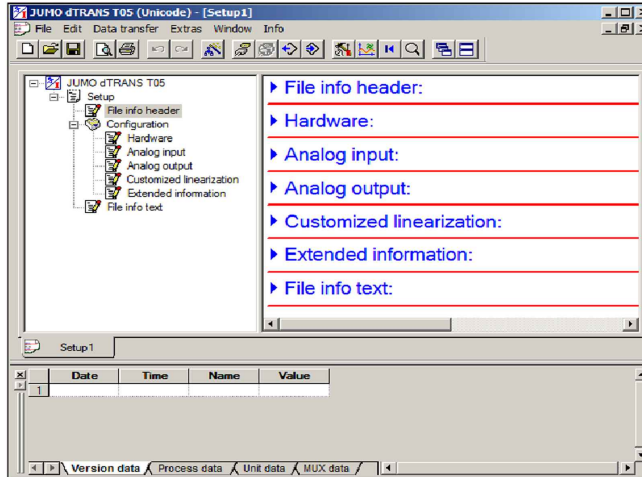

Configurable parameters

Sensor type	
Connection type 2/3-wire circuit or 4-wire circuit for RTD temperature probes or resistors/potentiometers	
Linearization	
Customer-specific linearization	
Sensor factor for thermocouple/RTD temperature probe	
Lead wire resistance with 2-wire circuit	
External or internal cold junction for thermocouple	
Scaling	
Digital filter	
Offset	
Unit	
Behavior in the event of a probe break/short-circuit	
Output signal increasing or decreasing (reversion)	
Output functions, current Type 705050 and type 705051	4 to 20 mA 4 to 20 mA scalable (start/end) Constant current source
Output functions, voltage Only type 705051	0 to 10 V 0 to 10 V scalable (start/end) Constant voltage source
TAG number (10-digit) and description (20-digit)	
Installation date	
Data pertaining to version, process and device of the transmitter can be displayed	

Hardware and software requirements

For operation and the installation of the setup program the following hardware and software requirements have to be met.

Microsoft ^a Windows ^a XP, Windows Vista, Windows 7 32-bit/64-bit
1 GB RAM
200 MB free hard disk space
1 USB interface

^a Microsoft and Windows are registered trademarks of Microsoft Corporation.

Connection diagram

The connection diagram in the data sheet provides preliminary information about the connection possibilities. Only use the operating manual for the electrical connection. The knowledge and the correct technical execution of the safety information/instructions contained in these documents are a prerequisite for installation, electrical connection, and startup as well as for safety during operation.

Connection example dTRANS T05 B

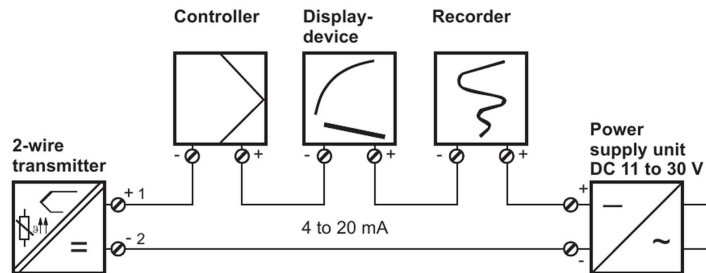

Terminal assignment and dimensions (mm) dTRANS T05 B

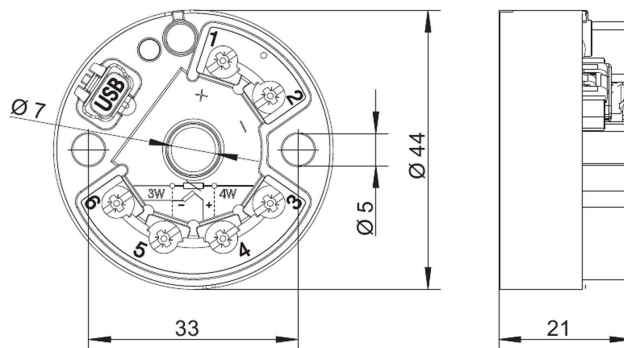

Connection for	Terminal assignment	
Voltage supply Type 707050 DC 11 to 35 V Current output 4 to 20 mA	$R_B = (U_b - 11 \text{ V})/22 \text{ mA}$ R_B = Load resistance U_b = Voltage supply	
Analog inputs		
RTD temperature probe 2-wire circuit	$R_L \leq 11 \Omega$ R_L = Lead resistance per wire	
RTD temperature probe 3-wire circuit (3W)	$R_L \leq 11 \Omega$ R_L = Lead resistance per wire	
RTD temperature probe 4-wire circuit (4W)	$R_L \leq 11 \Omega$ R_L = Lead resistance per wire	
Thermocouple		
Resistor/potentiometer 2-wire circuit	$R_L \leq 11 \Omega$ R_L = Lead resistance per wire	
Resistor/potentiometer 3-wire circuit (3W)	$R_L \leq 11 \Omega$ R_L = Lead resistance per wire	
Resistor/potentiometer 4-wire circuit (4W)	$R_L \leq 11 \Omega$ R_L = Lead resistance per wire	
Resistance transmitter	E = End S = Slider A = Start	
Voltage 0 to 1 V		

Connection example dTRANS T05 T

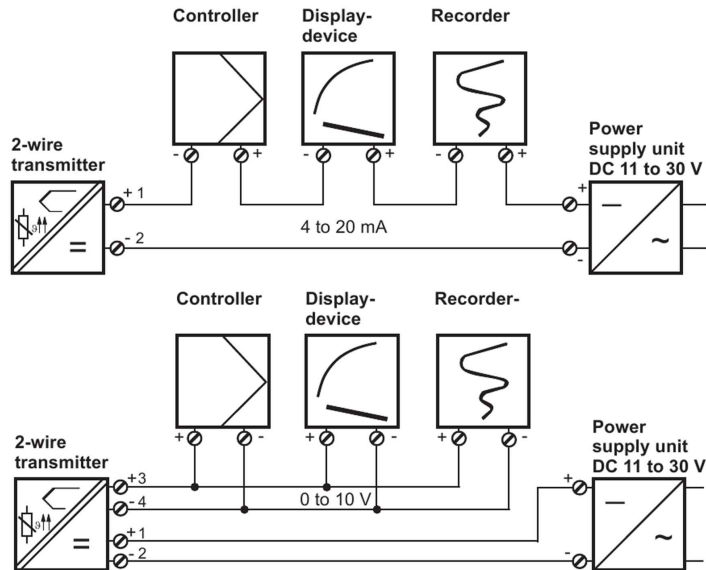

Connection assignment and dimensions (mm) dTRANS T05 T

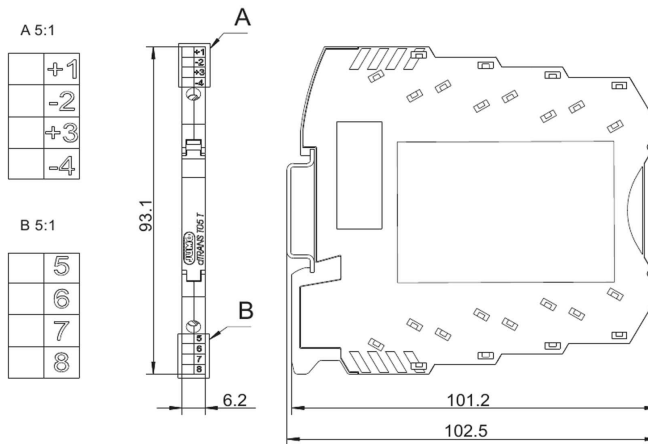

This figure shows type 707051 installed on a DIN rail TH 35-7.5. The specifications concerning dimensions only valid for the installation on this DIN rail and change accordingly if a DIN rail TH 35-15 is used.

Connection for	Terminal assignment									
Voltage supply Type 707051 DC 11 to 35 V	$R_B = (U_b - 11 \text{ V})/22 \text{ mA}$	<table style="border: none;"> <tr> <td style="text-align: center;">1</td> <td style="text-align: center;">2</td> </tr> <tr> <td style="text-align: center;">○</td> <td style="text-align: center;">○</td> </tr> <tr> <td style="text-align: center;"> </td> <td style="text-align: center;"> </td> </tr> <tr> <td style="text-align: center;">+</td> <td style="text-align: center;">-</td> </tr> </table>	1	2	○	○			+	-
1	2									
○	○									
+	-									
Current output 4 to 20 mA	$R_B = \text{Load resistance}$ $U_b = \text{Voltage supply}$									

Connection for	Terminal assignment	
Voltage output 0 to 10 V		
Analog inputs		
RTD temperature probe 2-wire circuit	$R_L \leq 11 \Omega$ R_L = Lead resistance per wire	
RTD temperature probe 3-wire circuit (3W)	$R_L \leq 11 \Omega$ R_L = Lead resistance per wire	
RTD temperature probe 4-wire circuit (4W)	$R_L \leq 11 \Omega$ R_L = Lead resistance per wire	
Thermocouple		
Resistor/potentiometer 2-wire circuit	$R_L \leq 11 \Omega$ R_L = Lead resistance per wire	
Resistor/potentiometer 3-wire circuit (3W)	$R_L \leq 11 \Omega$ R_L = Lead resistance per wire	
Resistor/potentiometer 4-wire circuit (4W)	$R_L \leq 11 \Omega$ R_L = Lead resistance per wire	
Resistance transmitter	E = End S = Slider A = Start	
Voltage 0 to 1 V		

PC interface for dTRANS T05, type B and T

Connection for	Type	Terminal assignment	
USB connection to the PC	USB interface 2.0 (Mini-B; "Full-Speed")	Standard (5-pin)	

Order details

(1) Basic type

707050 dTRANS T05 B - 2-wire transmitter

707051 dTRANS T05 T - 2-wire transmitter in mounting rail case

(2) Configuration

x	x	8	Factory-set (0 to 100 °C, Pt100 3-wire circuit, 4 to 20 mA)
x	x	9	Customer-specific setting

(3) Electrical connection type

x	x	06	Screw terminals
x		07	Spring-cage terminals

	(1)	/	(2)	-	(3)
Order code	<input type="text"/>	/	<input type="text"/>	-	<input type="text"/>
Order example	707050	/	8	-	06

Scope of delivery

1 transmitter in the version ordered
For type 707050: including fastening material (2 screws, 2 pressure springs, and 2 retaining washers)
1 operating manual B 707050.0

Accessories

Article	Part no.
Setup program on CD-ROM, multilingual	00574959
Operating manual B 707050.0	00576951
USB cable, A-connector on mini B-connector, length 3 m	00506252
Screw-on end clamp for mounting rail	00528648
Mounting element for installation of type 707050 on mounting rail	00352463