

Hygro Transducer / Hygrothermal Transducer and CO₂ Measuring Probe for Climate Monitoring

- For measuring relative air humidity, temperature, and carbon dioxide concentration
- For building automation, storage rooms, and climate/ventilation control
- Available in the indoor, wall-mounted, and duct version
- Miniature rod version for OEM applications
- With current or voltage outputs as well as passive temperature output
- Hygro thermometer as tabletop/wall-mounted indicator

These capacitive humidity transducers are conceived for the most common applications in heating, air conditioning, and ventilation technology. They distinguish themselves through their high measuring accuracy, excellent long-term stability, and good chemical resistance.

In the case of CO₂ measuring probes, a proven infrared technology is used. The used NDIR procedure (non-dispersive infrared technology) utilizes a patented auto calibration function and eliminates all aging effects.

The different combination possibilities between the process variables humidity (RH), temperature (T), and carbon dioxide (CO₂) as well as the optically pleasing and easily installable cases set new standards in HKL technology.

The measuring probe in the indoor, wall-mounted, or rod version allow for a very broad field of application. For the respective process variables standardized current and voltage outputs are available. For temperature, passive resistance outputs can be delivered as an option. Measuring probes in the indoor version can also be equipped with an optional LCD display that shows the respective measured values in alteration. If, however, only a simple display of the process variables is needed then the battery-powered tabletop/wall-mounted indicator is the ideal solution.

Applications can be found in all areas of ventilation technology and in building management. Examples are residential buildings, office buildings, public buildings, storage halls, and production halls.

The humidity transducers of "version A" have performed particularly well in fields that have high demands on humidity measuring technology (e.g. greenhouses, swimming pools, or stables). In addition, the devices are also very suitable for outdoor use and in meteorology. Here, we recommend the radiation protection that is available in the accessories as it supplies the appropriate forced ventilation. Another available accessory is sensor coating. In many cases it enables improved or even permanent operation in atmospheres that are especially polluted.



Technical data

Humidity (RH)

Humidity sensor	Capacitive, can take condensation (sensor coating available as an option)
Humidity measuring range	0 to 100 % RH
Humidity working range	10 to 90 % RH: Tabletop/wall-mounted indicator, indoor version
	10 to 95 % RH: Wall-mounted and duct version (version B)
	0 to 100 % RH: Wall-mounted and duct version (version A); rod version
Humidity accuracy at 20 °C	±2 % RH: Indoor version and indicator in the humidity range between 40 to 60 % RH, wall-mounted and duct version (version A) in the humidity range between 0 to 90 % RH (in the remaining range ±3 % RH)
	±3 % RH: Indoor version with CO ₂ in the humidity range between 30 to 70 % RH, wall-mounted and duct version (version B), rod version in the humidity range between 0 to 95 % RH (in the remaining range ±5 % RH)
Temperature dependency	±0.05 % RH/°C (typical)

Temperature (T)

Temperature sensor	Platinum-chip temperature sensor Pt1000 according to DIN EN 60751, tolerance class A (passively Pt100 as well)
Temperature measuring range	0 to 50 °C: Indoor version; wall-mounted and duct version (version B)
	-5 to +55 °C: Tabletop/wall-mounted indicator
	-20 to +80 °C: Wall-mounted and duct version (version A)
	-40 to +60 °C: Rod version
Accuracy temperature at 20 °C	±0.25 °C: Indoor version - voltage output
	±0.4 °C: Indoor version - current output
	±0.7 °C: Indoor version - current output (CO ₂)
	±0.3 °C: Wall-mounted and duct version (version A); tabletop/wall-mounted indicator
	±0.5 °C: Wall-mounted and duct version (version B); rod version

Carbon dioxide (CO₂)

Measuring principle	Non-dispersive infrared technology (NDIR)
Sensor	2-beam infrared cells
Measuring range	0 to 2000 ppm, 0 to 5000 ppm
	0 to 10000 ppm (duct version only)
Accuracy at +25 °C and 1013 mbar	±(50 ppm +2 % from measured value) for range 0 to 2000 ppm
	±(50 ppm +3 % from measured value) for range 0 to 5000 ppm
	±(100 ppm +5 % from measured value) for range 0 to 10000 ppm
Temperature dependency	2 ppm CO ₂ /°C (typical)
Long-term stability	20 ppm/a (typical)
Sampling rate	Approx. 15 s
Response time	< 195 s

Electrical data

Voltage supply	2× DC 1.5 V	Tabletop/wall-mounted indicator
	Alkaline batteries:	
	DC 15 to 35 V, AC 24 V ±20 %:	Humidity transducer with voltage output CO ₂ measuring probe
	DC 20 to 28 V:	Humidity transducer with current output
	DC 4.5 to 30 V:	Only rod version with voltage output
	DC 9 to 28 V:	Only rod version with current output
Self-supply	5 to 10 mA with DC voltage supply, max. 20 mA with AC-voltage supply	
	1.5 mA for rod version	
	10 mA + output current, max. 0.5 A for 0.3 s with CO ₂ measuring probe	
Load resistance	R _L max. 500 ohm with current output	
Output signals	4 to 20 mA, 0 to 1 V, 0 to 5 V, 0 to 10 V as well as Pt100, Pt1000 as passive temperature output (Basic types according to order details)	
Electromagnetic compatibility	EN 61326-1 and EN 61326-2-3	
Connection	Screw terminals max. 1.5 mm ²	
Connection diagram	See operating manual	

Case

Case	PC plastic	
Protection type	IP20: indoor version, tabletop/wall-mounted indicator	
	IP65: wall/duct/rod version	
Cable entry	M16 × 1.5 (optionally available with plug connector) wall-mounted and duct version	
Ambient temperature	-20 to +60 °C:	Indoor version and duct version (CO ₂)
	-5 to +55 °C:	Indoor version with LCD display, tabletop/wall-mounted indicator, wall-mounted and duct version (version B)
	-40 to +60 °C (measuring head 80 °C):	Wall-mounted and duct version (version A)
	-40 to +60 °C:	Rod version
Storage temperature	-25 to +60 °C	
Weight	Approx. 100 g	Indoor version and tabletop/wall-mounted indicator
	Approx. 150 g	Wall-mounted version
	Approx. 250 g	Duct version
	Approx. 115 g	Rod version (0.5 m)
	Approx. 180 g	Rod version (3 m)
	Approx. 290 g	Rod version (10 m)

Accessories

Filter	Plastic-grid membrane filter (standard): For small to normal contamination levels in the field of heating, air conditioning, and ventilation. Pore size 1 µm, $t_{10/90}$ approx. 15 s.
	Stainless steel sinter filter Most positive effects for high mechanical and thermic stresses. Unsuitable for high-humidity range. Pore size 10 µm, $t_{10/90}$ approx. 30 s.
	Plastic-grid power-line filter With high humidity, danger of condensation, or after rapidly changing humidity cycles. For average contamination level. Pore size 100 µm, $t_{10/90}$ approx. 7 s.
	PTFE filter: For high chemical resistance. Pore size 50 µm, $t_{10/90}$ approx 14 s.
Humidity sensor checks	To test the accuracy of humidity transducers, humidity sensor checks can be used. The test procedure is described in DIN 50008, IEC publication 260, ISO /R 483-1966. The basic principle consists of an appropriate climate being produced above an aqueous, saturated salt solution. Humidity sensor checks with values of 33 % RH, 53 % RH, and 76 % RH are available directly from the factory.
Radiation protection	For outdoor use the measuring probes in the wall-mounted and rod version can be equipped with radiation protection. The radiation protection causes forced ventilation and largely prevents the heat up of the measuring head through solar radiation (and therefore also prevents incorrect measuring values). Depending on the type of installation one wants, two basic types are available: Basic type 907021/20: radiation protection "HA010501" with mounting brackets for wall mounting. Basic type 907021/40: radiation protection "HA010502" with clamping ring.
Snap-in installation kit	The practical snap-in installation kit can be ordered as an option for the measuring probe. It essentially consists of a separate mounting plate and a plug connector on the device. This enables a fast and uncomplicated switch of transmitters. That feature is especially advantageous for frequent change interval, e.g. for replacement interval or for mobile applications.
Sensor coating	The sensor coating for the humidity sensor, which can also be ordered as an option, is an additional protective coating. It protects a humidity sensor even better against pollutants and, in many cases, allows a longer service life especially when dealing with polluted or aggressive atmospheres.

Dimensions

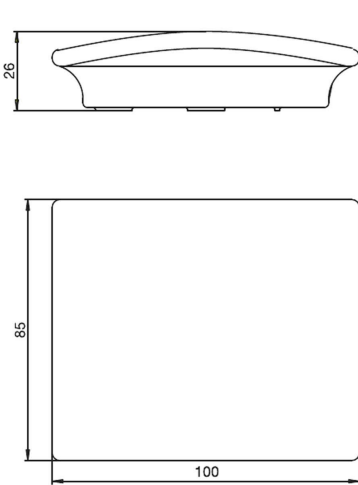

Indoor version
 Basic type 907021/11 and 907021/80
 As well as tabletop/wall-mounted indicator
 Basic type 907021/12

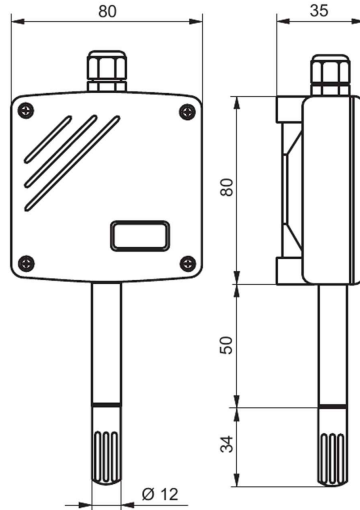

Wall-mounted versions
 Basic type 907021/20
 Basic type 907021/21

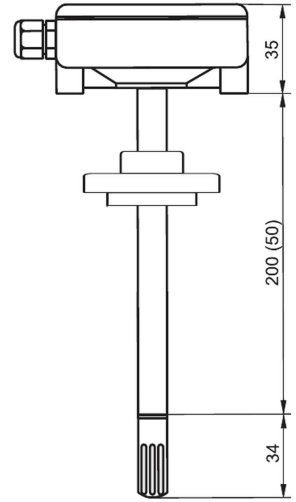

Duct versions
 Basic type 907021/30
 Basic type 907021/31
 Basic type 907021/85

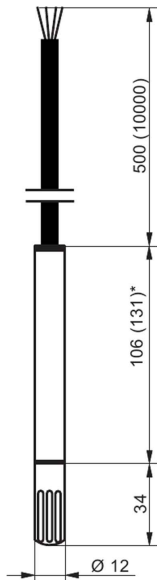

Rod version
 Basic type 907021/40
 * Valid length for current output

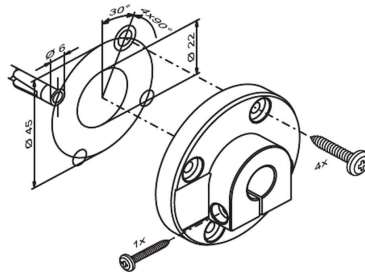

**Mounting flange
 for duct versions**

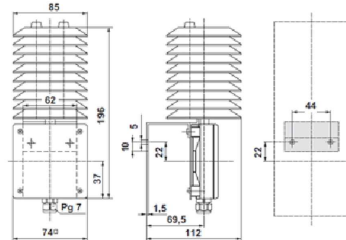

**Radiation protection
 "HA010501"**

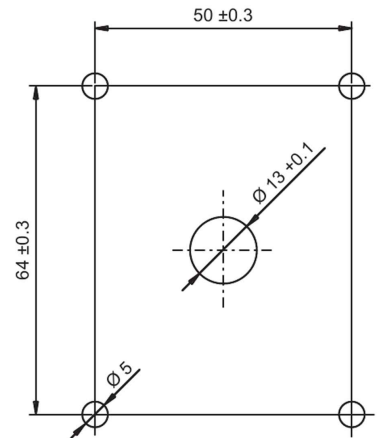

**Drilling template for
 wall-mounted and duct versions**

Order details: hygro transducer / hygrothermal transducer (capacitive) for climate monitoring

(1) Basic type				
	907021/11	Hygro transducer / hygrothermal transducer indoor version		
	907021/12	Hygro thermometer, tabletop/wall-mounted indicator		
	907021/20	Hygro transducer / hygrothermal transducer wall-mounted version (version A)		
	907021/21	Hygro transducer / hygrothermal transducer wall-mounted version (version B)		
	907021/30	Hygro transducer / hygrothermal transducer duct version (version A)		
	907021/31	Hygro transducer / hygrothermal transducer duct version (version B)		
	907021/40	Hygro transducer / hygrothermal transducer rod version		
(2) Version				
x	1	Humidity (1-channel output)		
x x	2	Humidity and temperature		
x	3	Humidity and temperature (T passive)		
(3) Measuring ranges¹				
x	33	10 to 95 % RH; -5 to +55 °C		
	34	0 to 100 % RH; 0 to 50 °C		
	10	0 to 100 % RH; -20 to +80 °C		
	14	0 to 100 % RH; -40 to +60 °C		
	22	0 to 100 % RH; -30 to +70 °C		
(4) Output signals				
	000	No output, only display		
x	005	4 to 20 mA / 4 to 20 mA		
x	006	4 to 20 mA / temperature (T passive) Pt100, class A		
x	007	4 to 20 mA / temperature (T passive) Pt1000, class A		
	051	0 to 1 V / 0 to 1 V		
	052	0 to 1 V / temperature (T passive) Pt100, class A		
	053	0 to 1 V / temperature (T passive) Pt1000, class A		
	057	0 to 5 V / 0 to 5 V		
x	065	0 to 10 V / 0 to 10 V / (0 to 10 V)		
x	066	0 to 10 V / temperature (T passive) Pt100, class A		
x	067	0 to 10 V / temperature (T passive) Pt1000, class A		
(5) Extra codes				
x	000	Without extra code		
x	793	Integrated LCD display (in case of several measured values) (not for T passive)		
x	794	Integrated LCD display (as in extra code 793), but temperature display in °F (not for T passive)		
	764	Snap-in installation kit (mounting plate and plug connector), not for temperature (T passive)		
	796	Probe (short version for duct version, length 50 mm), not for CO ₂ and T passive		
	847	Longer connecting cable - length 3 m		
	849	Longer connecting cable - length 10 m		
	860	Sensor coating		

	(1)	(2)	(3)	(4)	(5)				
Order code	<input type="text"/>	-	<input type="text"/>	-	<input type="text"/>	/	<input type="text"/>	, ... ²	
Order example	907021/11	-	2	-	34	-	065	/	000

Note:

Please note the humidity working range and the admissible ambient temperature (see "Technical data" in data sheet 907021). A second or a third output is only available in multichannel devices and is not always possible with all device combinations.

¹ Please note humidity working area in Technical Data!

² List extra codes in sequence, separated by commas.

Order details: CO₂ measuring probe for climate monitoring
(1) Basic type

907021/80	CO ₂ measuring probe indoor version
907021/85	CO ₂ measuring probe duct version

(2) Version

x	4	CO ₂
x	5	CO ₂ and temperature
x	6	CO ₂ and temperature (T passive)
x	7	CO ₂ , temperature and humidity (only for 0 to 10 V)

(3) Measuring range

x	40	0 to 2000 ppm; 0 to 50 °C; 0 to 100 % RH
x	41	0 to 5000 ppm; 0 to 50 °C; 0 to 100 % RH
x	42	0 to 10000 ppm; 0 to 50 °C; 0 to 100 % RH

(4) Output signals

x	005	4 to 20 mA / 4 to 20 mA
x	006	4 to 20 mA / temperature (T passive) Pt100, class A
x	007	4 to 20 mA / temperature (T passive) Pt1000, class A
x	065	0 to 10 V / 0 to 10 V / (0 to 10 V)
x	066	0 to 10 V / temperature (T passive) Pt100, class A
x	067	0 to 10 V / temperature (T passive) Pt1000, class A

(5) Extra codes

x	000	Without extra code
x	793	Integrated LCD display (in case of several process values, alternating display) (not for T passive)
x	794	Integrated LCD display (as in extra code 793), but temperature display in °F (not for T passive)

Order code	(1)	-	(2)	-	(3)	-	(4)	/	(5)	, ... ¹
Order example	907021/80	-	5	-	40	-	005	/	000	

Note:

Please note the humidity working range and the admissible ambient temperature (see "Technical data" in data sheet 907021). A second or a third output is only available in multichannel devices and is not always possible with all device combinations.

¹ List extra codes in sequence, separated by commas.

Stock versions

Order code	Part no.
907021/11-1-34-005/000	00436297
907021/11-2-34-005/000	00436298
907021/11-2-34-005/793	00441452
907021/12-2-33-000/000	00440647
907021/20-1-10-005/000	00388170
907021/20-2-10-005/000	00388171
907021/21-1-34-005/000	00388172
907021/21-2-34-005/000	00388173
907021/30-1-10-005/000	00388174
907021/30-2-10-005/000	00388175
907021/31-1-34-005/000	00388176
907021/31-2-34-005/000	00388177
907021/40-1-14-051/000	00388179
907021/40-2-14-051/000	00388180
907021/80-5-40-005/000	00578092
907021/80-5-40-005/793	00578093
907021/80-7-40-065/793	00578094
907021/85-4-40-005/000	00578095
907021/85-6-40-007/000	00578097

Accessories

Article	Part no.
Plastic-grid membrane filter "HA010101"	00388181
Stainless steel sinter filter "HA010103"	00388183
Plastic-grid power-line filter "HA010106"	00389114
PTFE filter "HA010105"	00503575
Humidity sensor check 33 % RH	00332758
Humidity sensor check 53 % RH	00332754
Humidity sensor check 76 % RH	00332760
Radiation protection "HA010501" for basic type 907021/20	00388013
Radiation protection "HA010502" for basic type 907021/40	00573116